



# Moulding a reputation for quality and reliability in Africa

Pan Mixers South Africa (PMSA) – the largest supplier of concrete brick, block and paving-making machinery and technology in Africa – boasts a comprehensive range of precision block, brick and paving making moulds manufactured by German-based RAMPF.

**P**MSA marketing and sales manager, Quintin Booysen, notes that RAMPF offers a wide range of products that are ideally suited to PMSA's client base. "RAMPF manufactures internationally recognised concrete moulds, paving and building bricks, kerbstones, concrete planters, dry wall systems and building brick moulds, which add substantial value to construction and building projects where precast products are specified and used."

Booyesen points out that a wide range of RAMPF products are available through PMSA, including paver moulds, concrete moulds, CSI diamond exchange hollow block moulds, and vibration table controllers. "The technology utilised in these moulds offers numerous advantages for clients, particularly longer wear life, which is important in the precast market," he explains.

RAMPF's proprietary CSI diamond hardening technology allows for a hardness of up to 68 HRC, thereby ensuring a considerably prolonged lifespan of the mould, even when it is exposed to highly abrasive types of gravel, crushed stone and other aggregates that cause wear and tear. With the rising cost of steel, this offers the client a clear cost advantage.

Booyesen reveals that RAMPF CSI diamond exchange hollow block moulds make use of a special hardened steel which improves resistance to wear. "The components of the hollow block moulds are bolted and not welded together, which means that there is quick and easy replacement of damaged or worn parts. What's more, individual components are easily replaced, resulting in improved turnaround times and cost savings with regards to maintenance and service."

RAMPF also boasts a mould slip system that protects all models of tamper shoes and moulds more effectively against wear. Booyesen continues, "The mould slip system increases the number of cycles and reduces the reject rate of the mould. It also allows for quick change from mould to mould."

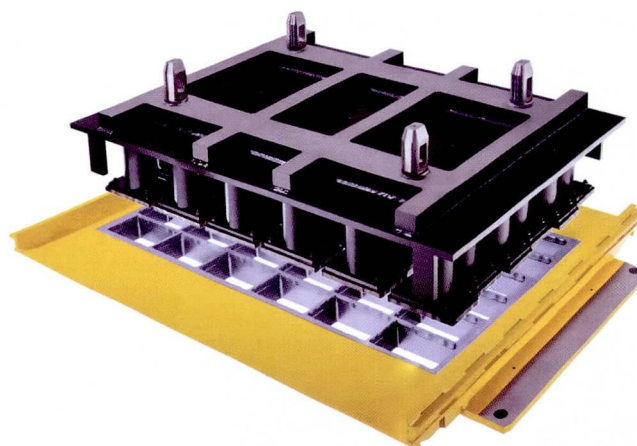

Another innovative RAMPF product available locally through PMSA is the vibration table controller for optimal process parameters. Booyesen states that it guarantees perfect utilisation of the vibration energy. "The vibration table controller offers the user both mould and machine protection, as well as uniformity of paving, brick, or blocks manufactured, with regards to height and density. There is also an increase in the level of production with a reduction in mould wear and cracking."

Booyesen believes that the RAMPF range of products available from PMSA can withstand the tough African terrain, making it ideal for any local concrete moulding application.

"The advantages of the RAMPF range of products are boundless and ideal for our clients, as the moulds last longer and maintenance is easier and less time consuming, when compared to other brands," he concludes.

PMSA's client CEL Paving – a CMA award winning company producing top quality paving products – recently purchased two RAMPF moulds, one for its new RE1400 block machine currently being manufactured by PMSA and a second RAMPF mould for its existing VB4X block making machine.